

release thread 3x M6

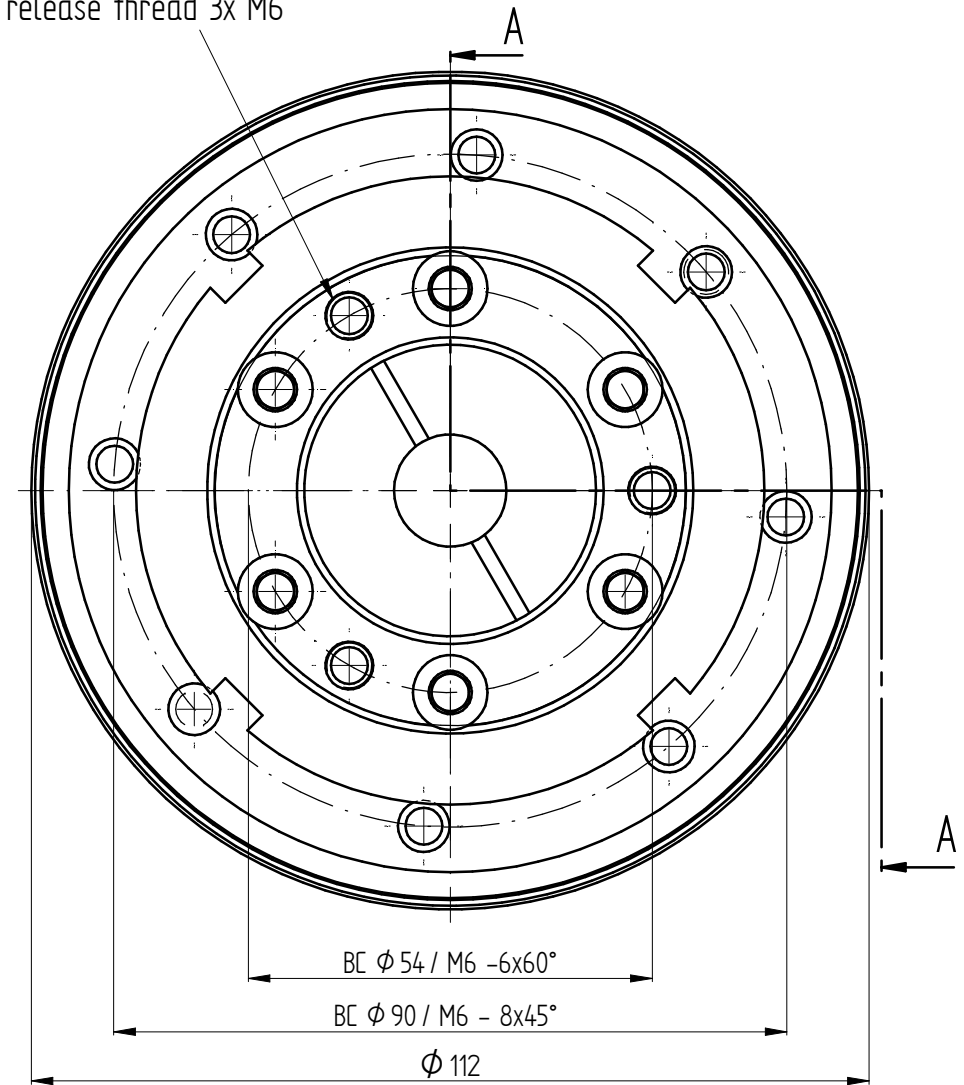

technical data:

setting range:	160 - 380 Nm
mass:	2,5 Kg
moment of inertia:	0,003 kgm ²
max. radial load / FR:	90 kN
$\phi \square$ min/max:	$\phi 22 - \phi 38\text{mm}$
material:	heat treated steel

Anforderung		gepr.		Datum		Name		Werkstoffbezeichnung		Werkstoffnummer		Maßstab			
		21.03.23		AR				-		-		1,4			
Passung		Abmaß		gez.		10.03.23		IA		Rohteil-/Vorteilnummer		Gewicht			
DIN ISO 13715		DIN ISO 2768-mK								-		kg			
-0,4		0,5 ... 6 ± 0,1								safety coupling SKR-K 380 - standard					
+0,8		6 ... 30 ± 0,2										Format A3		Artikelnummer	
		30 ... 120 ± 0,3										MB - 005 24303- e		Ersatz für	
		120 ... 315 ± 0,5								-		-			
		315 ... 1000 ± 0,8								-		-			
						D-63839-Kleinwallstadt				-		ersetzt durch			