

Safety Couplings I Series SKR for indirect drives

- Series SKR-K with cone clamping bush
- Series SKR-N with keyway connection
- robust slide bearing for high bearing forces and best concentricity
- compact attachment and optimum pane integration

technical data:

SKR Size	setting range disengagement torque T_{KA} [Nm]	moment of inertia [10^{-3}kgm^2]	mass. approx. [kg]	tightening torque of screws 6x i - ISO 4762 [Nm]	max. lateral load F_R [kN]	bore diameters $\varnothing D$	
						DK from-to	DN from-to
25	10 - 25					8 - 22	8 - 30
40	16 - 40	0,5	0,8	M4 - (3)	40	10 - 22	10 - 30
80	30 - 80					14 - 22	12 - 30
105	50 - 105					12 - 38	12 - 50
180	80 - 180	3	2,5	M6 - (12)	90	14 - 38	16 - 50
380	160 - 380					22 - 38	20 - 50
650	300 - 650	11	5,5	M8 - (30)	150	22 - 48	22 - 65
950	350 - 950					22 - 48	30 - 65
1100	500 - 1100					28 - 70	30 - 95
2200	1000 - 2200	55	14	M10 - (60)	250	42 - 70	45 - 95
3200	1500 - 3200					55 - 70	52 - 95

material:

heat-treated steel. temperature range: -30°C up to $+200^\circ\text{C}$



SKR-N



SKR-K

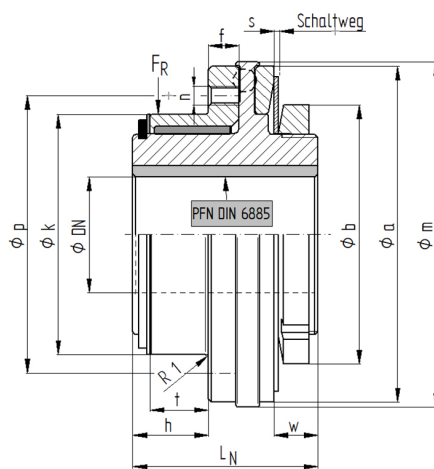

SKR-N

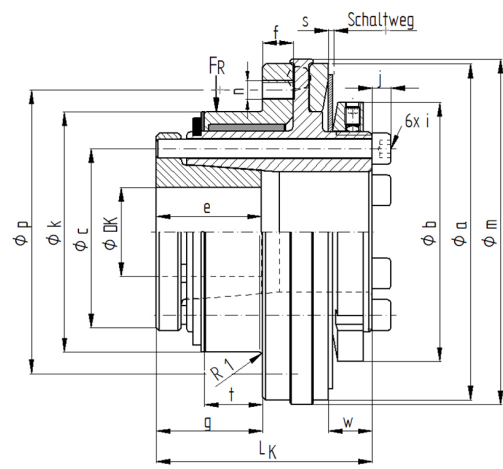

SKR-K

Dimensions [mm]: length dimensions according to DIN ISO 2768 cH

SKR	$\varnothing a$	$\varnothing b$	$\varnothing c$	e	f	g	h	j	$\varnothing k^{h7}$	$\varnothing m$	$\varnothing p$	L_K	L_N	n	s	t	w
25/40/80	73,5	52	33	23	7	24	17,2	4	50	77	59	50	43	8xM4	1,2	12,5	10,3
105/180/380	109	84	54	34	10	34,5	24,5	6	78	112	90	70x	60	8xM6	1,6	19	14,2
650/950	139	105	66	37	14	42,5	30	8	100	145	115	90,5	78	8xM8	1,9	24	20
1100/2200/3200	188	170	97	51	14	51,5	36	10	140	196	160	120,5	105	12xM10	3,0	28	35,6

order example: SKR-K 105 - D = 22^{G6} - release torque - TKA = 75 Nm