

Safety Coupling I Series SKB for indirect drives

- /// simple installation with clamping ring hub
- /// with integral ball bearing
- /// for high axial and lateral loads
- /// excellent run-out accuracy

technical data:

SKB size	setting range disengagement torque T_{KA} [Nm]	moment of inertia [10 ⁻³ kgm ²]	mass approx. [kg]	tightening torque of screws i [Nm]	max. lateral load F_R [N]	bore diameters $\varnothing D$					
						min	max	max. bore- \varnothing keyway DIN 6885			
1	0,5 - 1	0,044	0,22	M5 - [8]	2550	5	14	10			
2	1 - 2										
6	2 - 6	0,09	0,36	M5 - [8]	5000	6	16	12			
12	6 - 12										
15	8 - 15	0,36	0,8	M6 - [16]	8000	10	25,4	20			
30	13 - 30										
45	22 - 45										
60	25 - 60	1,1	1,5	M8 - [35]	9500	18	35	32			
100	40 - 100										
150	60 - 150										
230	80 - 230										
330	130 - 330	4,2	3,3	M10 - [70]	23000	24	44	38			
500	200 - 500										
800	350 - 800	12,2	6,2	M14 - [200]	30000	28	58	50			
1000	500 - 1000										
2000	800 - 2000	76	20	2xM16 - [250]	50000	42	100	90			
3000	1500 - 3000										
6000	3000 - 6000										
9000	3000 - 9000	240	34	10xM10 - [50]	65000	60	120	Optional			

temperature range: -30°C up to +200°C

material:
heat-treated steel
optional in stainless version

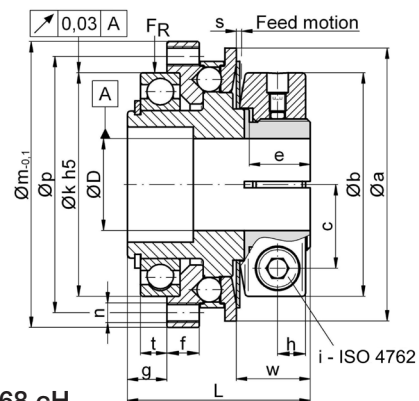

Dimensions [mm]: length dimensions according to DIN ISO 2768 cH

SKB	$\varnothing a$	($\varnothing a^*$)	$\varnothing b$	c	e	f	g	h	$\varnothing k^{h5}$	$\varnothing m$	$\varnothing p$	L	n	s	t	w
1/2	42	-	38	13,5	13	6	6	6	30	40	35	33,5	6xM3	0,8	4	14,6
6/12	48	(42)*	38,5	13,5	13	8	9,8	6	42	52	47	41	6xM3	0,9	7	15,8
15/30/45	66	(60)*	53	19,5	15	9	11,5	7,5	55	69	62	48	6xM4	1,2	8	18,5
60/100/150	83	(76)*	68	25,5	18,5	9	12	8,5	68	87	78	55,5	6xM6	1,6	8	22,4
230/330	109	(104)*	87	32	21	14	16,5	10,5	90	113	102	71,5	6xM8	1,8	12	25,6
500/800	132	-	115	42	30	15	17	13,5	110	136	124	87,5	8xM8	2,5	12	37
1000/2000	185	-	172	69	76	16	28	17/30	140	181	165	142±2	12xM10	3,7	21,5	77
3000/9000	236	-	215	$\varnothing 160$	82	18/14	22	-	180	243	200/225	166	12xM10	3,0	14	87

For size 3000 - 9000 shrink disk clamping instead of clamping ring design

*note: smaller outer diameters of the thrust plate are possible (see values in brackets)

order example:

SKB 30 -

D = 24 ^{H7} -

$T_{KA} = 25$ Nm