

Safety Couplings I Series SKB-KP for direct drives

- with bellows attachment • with lateral clamping hub on both sides
- EASY-clamping hub on bellows side • compensation of misalignments • low restoring forces

technical data:

SKB-KP size	setting range disengagement torque T_{KA} [Nm]	moment of inertia $[10^{-3} \text{kgm}^2]$	mass approx. [kg]	torsional stiffness [Nm/arcmin]	max. shaft mis-alignment [mm]		tightening torque of screws		$\varnothing D1$ min max		$\varnothing D2$ min max		$\varnothing D2$ max. PFN 6885
					axial \pm	lateral	f [Nm]	i [Nm]					
1,5	0,3 - 1,5	0,015	0,14	0,9	0,3	0,1	M3-[2]	M3-[2]	5	11	6	12,7	10
3	1 - 3								5	11	6	12,7	
6	2 - 6	0,13	0,45	2,1	0,5	0,15	M5-[8]	M5-[8]	6	24	6	16	12
12	6 - 12								8	24	8	16	
15	8 - 15	0,5	1,0	9	0,5	0,2	M6-[14]	M6-[16]	8	32	10	25,4	20
30	13 - 30								10	32	12	25,4	
45	22 - 45	1,5	1,9	20	0,6	0,2	M8-[30]	M8-[35]	12	32	14	25,4	32
60	25 - 60								13	38	18	35	
100	40 - 100	5,5	3,8	28	0,8	0,2	M10-[50]	M10-[70]	14	38	18	35	38
150	60 - 150								21	38	24	35	
230	80 - 230	14,0	6,8	52	0,8	0,2	M12-[90]	M14-[200]	24	43	24	44	50
330	130 - 330								32	43	32	44	
500	200 - 500	17,2	8,3	106	0,7	0,2	M14-[140]	M14-[200]	35	55	28	58	90
800	350 - 800								42	68	40	58	
1000	500 - 1000	80	20	150	0,8	0,2	M14-[140]	2xM16-[250]	45	75	42	100	90
2000	800 - 2000								45	90	45	100	
3000	1500 - 3000	380	50	1000	3	1,4	10xM12[70]	10xM10[50]	50	130	50	120	Opt.
6000	3000 - 6000								60	130	60	120	
9000	6000 - 9000	1000				1,4			80	130	80	120	

(*) note: reduced tightening torque for bigger hub bore diameter - see also $\varnothing D1/D2$ max!
temperature range: -30°C up to $+200^{\circ}\text{C}$

material:
safety part: heat-treated steel
clamping hub: high-tensile aluminum
hub 2000-9000: steel
bellows: stainless steel
screws: ISO 4762 / 12.9

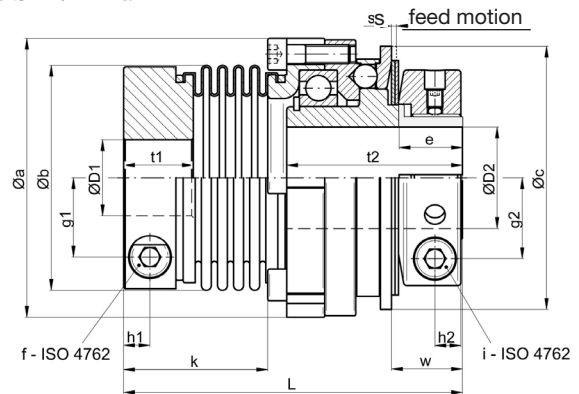

Dimensions [mm]: length dimensions according to DIN ISO 2768 cH

SKB-KP	$\varnothing a$	$\varnothing b$	$\varnothing c$	e	g1	g2	h1	h2	k	$L_{\pm 1}$	s	t1	t2	w
1,5/3	33	24	32	8	7,3	10,1	4,5	4	20,5	48,5	0,5	9,5	26,5	12,4
6/12	52,5	40(45)	48	14	13	13,5	6	6	36,6	81	0,9	16,5	41	16
15/30/45	69	56	66	16	19	19,5	8	7,5	43	94,5	1,2	20	48	18,5
60/100/150	88	71	83	20	25	25,5	9	8,5	45,5	107	1,6	22	55,5	22
230/330	115	82	109	23	28,5	32	11,5	10,5	52	132	1,8	26	72	26
500	137	101	132	32	35	42	13	13,5	60	156	2,5	29	87,5	37
800	137	122	132	32	42	42	16	13,5	74,5	170	2,5	34	87,5	37
1000	181	133	185	74	47	69	18,5	17/30	87,5	220 ± 2	3,7	45	89	74
2000	181	157	185	74	58	69	22	17/30	112	241	3,7	45	89	74
3000-9000	243	236	236	54	$\varnothing 175$	$\varnothing 160$	-	-	-	336	3,0	74	81	87

note: alternative lengths of bellows are possible on request; bellows side with conical hub: see series SKB-KS
setting range up to 9000Nm see series SKY-KS

order example: SKB-KP 30 - $D1 = 28^{G6}$ - $D1 = 24^{H7}$ - $T_{KA} = 25 \text{ Nm}$