

Elastomer Coupling I Series EKM-VA

/// stainless steel design - easy to assemble clamping hub /// backlash-free
/// plug-in /// compact /// vibration-damping

stainless
steel

technical data:

EKM-VA size	nominal torque [Nm]	hardness [shore]	moment of inertia [10^{-3} kgm ²]	torsional stiffness (stat. $0,5 \times T_N$) [Nm/arcmin]	max. shaft misalignment (mm)		lateral spring rate [N/mm]	max. speed [rpm]	mass ca. [kg]
					axial \pm	lateral			
6	6	98 Sh-A	0,26	0,09	0,5	0,1	600	29000	0,2
12	12	98 Sh-A	0,08	0,24	0,5	0,1	2100	23000	0,4
16	16	72 Sh-D	0,08	0,46	0,5	0,1	2900	23000	0,4
50	50	98 Sh-A	0,48	1	0,5	0,1	2600	17000	1
70	70	72 Sh-D	0,48	2	0,5	0,1	3700	17000	1
100	100	98 Sh-A	1	1,2	1	0,1	3300	15000	1,6
140	140	72 Sh-D	1	2,3	1	0,07	4600	15000	1,6
220	220	98 Sh-A	2,7	3,6	1	0,12	4500	12000	2,8
350	350	98 Sh-A	7	4,5	1	0,15	5900	9500	5
480	480	98 Sh-A	14	8	1	0,15	7000	8000	7
650	650	72 Sh-D	14	12	1	0,1	9600	8000	7

temperature range: -30°C up to +90°C or -20°C up to +120°C

material:

hubs: stainless steel 1.4305

elastomer spider: Polyurethan

screws: ISO 4762

stainless steel A4-80

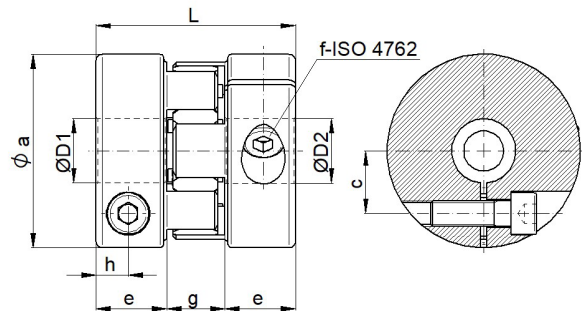

- Standard versions with stainless steel screws A4-80 - note the reduced tightening torque!
- Optionally with coated screws of strength class 12.9 for higher clamping forces or torques

Dimensions [mm]: length dimensions according to DIN ISO 2768 cH

EKM-VA	Ø a	c	e	g	h	L	f-T _s	Ø D 1/2 min	Ø D 1/2 max	Ø D 1/2 prebored
6	33	11	13,5	13	6	40	M4 - 2,5 Nm	6	16	5
12	41	13	17	16	8	50	M5 - 5 Nm	8	20	6,1
16	41	13	17	16	8	50	M5 - 5 Nm	10	20	6,1
50	64	20,5	22	18	10	62	M8 - 24 Nm	13	30	12
70	64	20,5	22	18	10	62	M8 - 24 Nm	15	30	12
100	73	23	26,5	20	12	73	M10 - 45 Nm	16	32	15
140	73	23	26,5	20	12	73	M10 - 45 Nm	18	32	15
220	87	29	31	24	14	86	M12 - 80 Nm	20	42	18
350	107	36	35	28	17	98	M14 - 110 Nm	24	55	20
480	121	44	38	33	18	109	M14 - 110 Nm	32	70	24
650	121	44	38	33	18	109	M14 - 110 Nm	42	70	24

note: Øa: interfering edge - screw head

order example: EKM-VA 220 - D1 = 32^{G6} D2=38^{G6}